



CLAY

Zanellato/Bortotto, 2025

An armchair that strikes a balance between design and craftsmanship, characterised by the presence of a ceramic slab on the backrest, handmade in the historic district of Nove, Vicenza.

Like a small work of art perfectly embedded in a textile painting, the glazed surface enhances the characteristics of the material, restoring its lustre and precious chromatic refractions. A formal lightness also underlined by the base, a linear base in oak or walnut that supports the seat and transforms it into a floating volume.

CLAY

Zanellato/Bortotto, 2025

TECHNICAL INFORMATION

SEAT STRUCTURE

Elastic webbed frame in plywood and solid fir wood, differentiated-density polyurethane foam.

BACKREST STRUCTURE

Plywood and solid fir wood frame with differentiated-density polyurethane foam. A hand-glazed ceramic plate is fixed to the back.

STRUCTURE

MDF base veneered in oak and Canaletto walnut. Back panel in birch plywood. Screw-fastened polypropylene glides.

SEAT HEIGHT

Without applied load: 42 cm.

UPHOLSTERY

The Clay armchair features a fully removable cover.

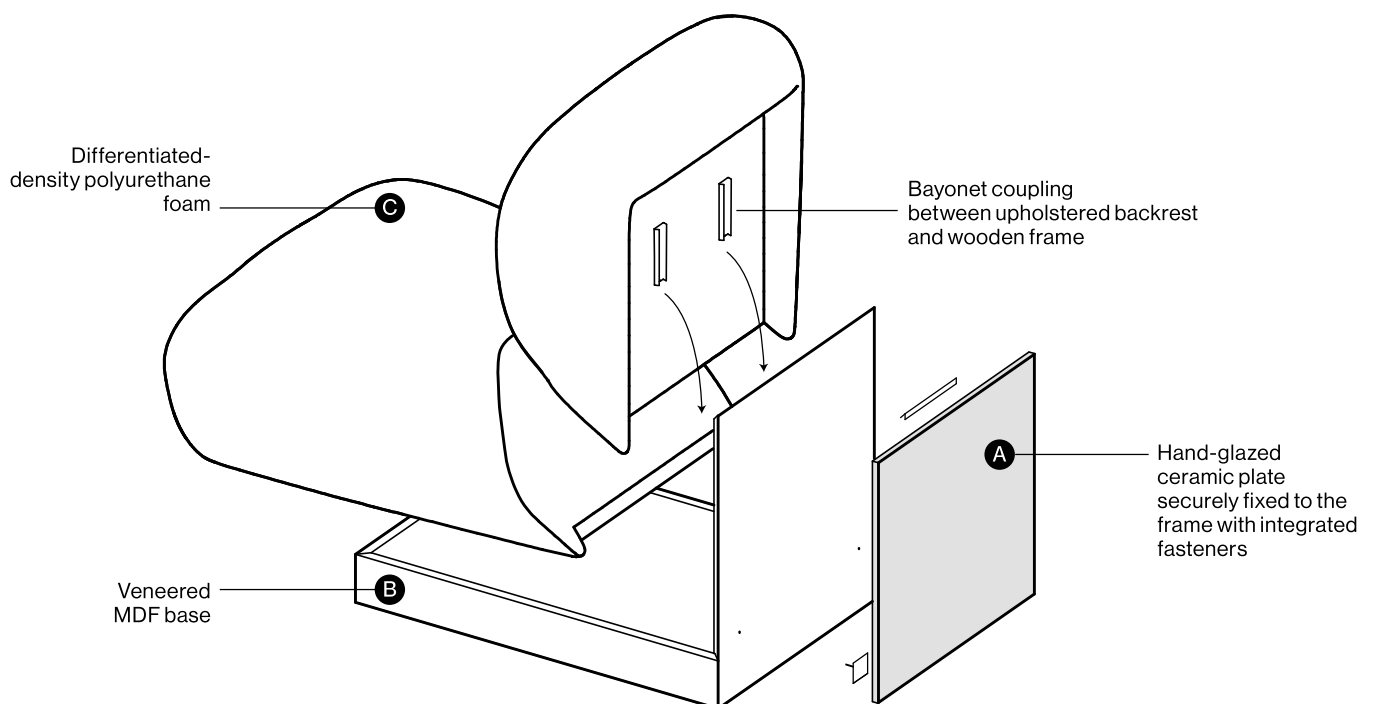

CL2001

Armchair

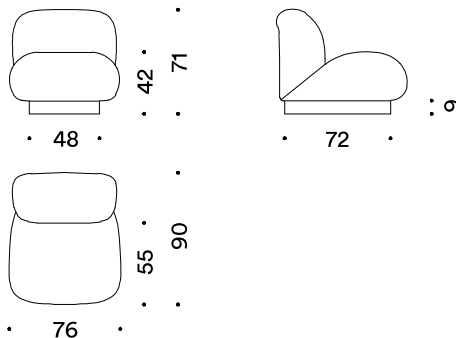

Moroso reserves the right to modify any design and change any technical specifications of any product at any time without prior notice. The drawings do not define the product details; the dimensions reported are indicative and may be subject to change.

USAGE CATEGORIES

S Soft Use
cosy and natural, with limited wear resistance

DASDIA bouclé

M Medium Use
robust and durable, easy to maintain

FUZZY bouclé
GORGONE bouclé
LHATI chenille

H Heavy Use
high technical values, very robust and durable

ZANZIBAR velvet

BOUCLÉ



S DASDIA

Typology: bouclé
Composition: 45% cotton, 16% viscose, 14% wool, 13% acrylic, 10% linen, 2% polyamide
Height: appr. 140 cm
Abrasion resistance: 35.000 cycles
Pilling resistance: 4

Hanger: **Toppings**
154 + 155

CAT. **S**

*Check with your Moroso representative to evaluate modifications, additions and available colours.
The use of customer own fabric is possible previous technical verification by the company.*



M FUZZY

Typology: bouclé
Composition: 48% viscose, 36% wool, 13% cotton, 3% polyamide
Height: appr. 140 cm
Weight: 550 g/sqm
Abrasion resistance: 40.000 cycles
Colour fastness to artificial light: 6
Pilling resistance: 4-5

Hanger: **Toppings**
154 + 155

CAT. **W**

*Check with your Moroso representative to evaluate modifications, additions and available colours.
The use of customer own fabric is possible previous technical verification by the company.*



M GORGONE

Typology: elastic bouclé
Composition: 33% viscose, 28% acrylic, 14% wool, 9% cotton, 7% polyester, 6% linen, 2% polyamide, 1% elastan
Height: appr. 148 cm
Weight: 860 g/sqm
Abrasion resistance: 60.000 cycles
Rubbing fastness: 4-5 (dry)
Colour fastness to artificial light: 5
Pilling resistance: 4

Hanger: **Touch Me**
158

CAT. **W**

*Check with your Moroso representative to evaluate modifications, additions and available colours.
The use of customer own fabric is possible previous technical verification by the company.*

COVERS: Covers must be washed or cleaned according to the instructions reported on the product label. In case of stains, always contact an authorised centre.

DISPOSAL: in order to respect the environment, it is recommended, at the end of the product's life, to separate the various component parts as much as possible and follow the respective recycling, recovery or disposal procedures in accordance with the regulations in force in the countries concerned.

CHENILLES

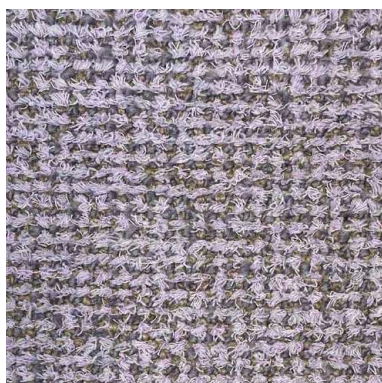

M LHATI

Typology: chenille

Composition: 36% acrylic, 35% polyester, 29% cotton

Height: approx. 140 cm

Weight: 800 g/sqm

Abrasion resistance: 50.000 cycles

Colour fastness to artificial light: 5/6

Pilling resistance: 4

Hanger: **Toppings + Touch Me** CAT. **W 154 + 158**

Check with your Moroso representative to evaluate modifications, additions and available colours.

The use of customer own fabric is possible previous technical verification by the company.

**In the hanger Toppings 154 it is possible to use also the Fury fabrics.*

VELVETS



H ZANZIBAR

Typology: velvet

Composition: 100% mohair (base: cotton)

Height: approx. 140 cm

Weight: 575 g/sqm

Abrasion resistance: 80.000 cycles

Rubbing fastness: 4-5 (dry) 4-5 (wet)

Colour fastness to artificial light: 5

Pilling resistance: 4-5

Hanger: **Velvets and Furs** CAT. **Z 152**

Check with your Moroso representative to evaluate modifications, additions and available colours.

The use of customer own fabric is possible previous technical verification by the company.

COVERS: Covers must be washed or cleaned according to the instructions reported on the product label. In case of stains, always contact an authorised centre.

DISPOSAL: in order to respect the environment, it is recommended, at the end of the product's life, to separate the various component parts as much as possible and follow the respective recycling, recovery or disposal procedures in accordance with the regulations in force in the countries concerned.

CLAY

Zanellato/Bortotto, 2025

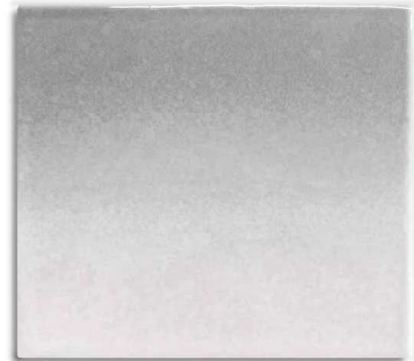
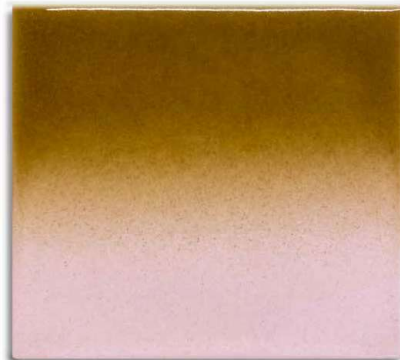
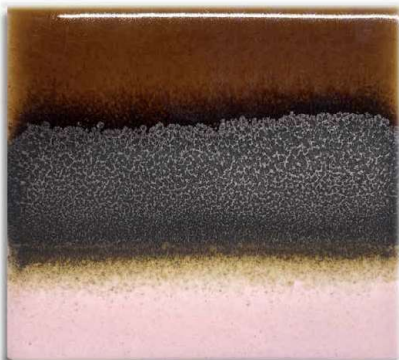
CERAMIC PLATES**COLOUR VARIANTS****DEEP WATER**
- monochrome**SANDY PINK**
- monochrome**SILVER CLOUD**
- monochrome**SUMMER ICE CREAM**
- two-tone gradient**ROSE WOOD**
- two-tone gradient**NIGHTY MEADOW**
- two-tone gradient**SALTED CARAMEL**
- three-tone gradient**MIDNIGHT SWIM**
- three-tone gradient**ACQUA ALTA**
- three-tone gradient

FINISHES: for any doubts or further information regarding care and cleaning, please contact your Moroso representative.

DISPOSAL: in order to respect the environment, it is recommended, at the end of the product's life, to separate the various component parts as much as possible and follow the respective recycling, recovery or disposal procedures in accordance with the regulations in force in the countries concerned.

CERAMIC PLATES

COLOUR VARIANTS AND CONFIGURATION OPTIONS

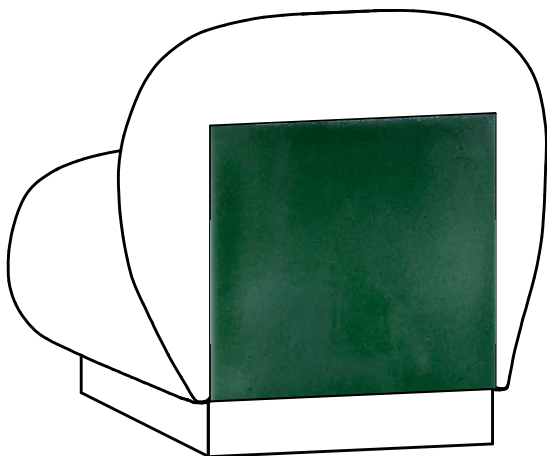

DEEP WATER
- monochrome
- **A variant**

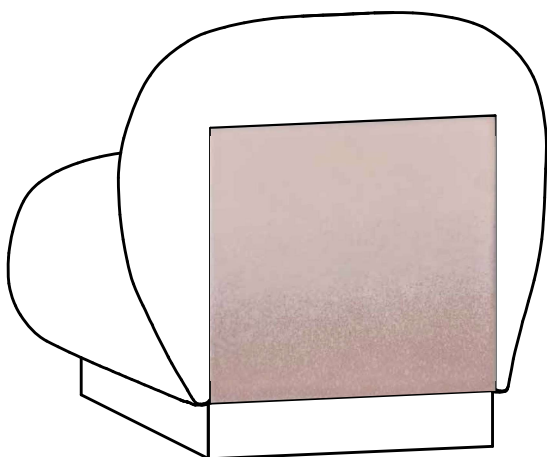

SANDY PINK
- monochrome
- **A variant**: darker pink tone DOWN

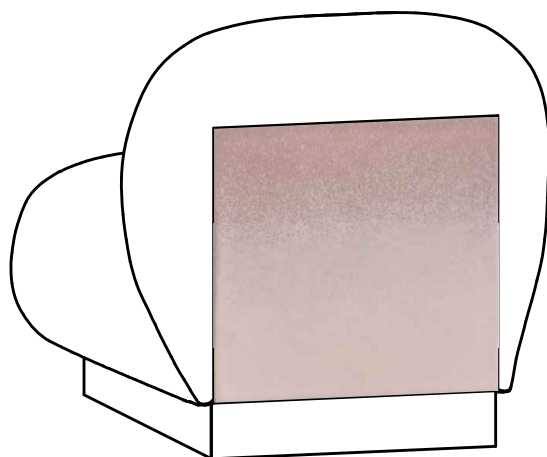

SANDY PINK
- monochrome
- **B variant**: darker pink tone UP

FINISHES: for any doubts or further information regarding care and cleaning, please contact your Moroso representative.

DISPOSAL: in order to respect the environment, it is recommended, at the end of the product's life, to separate the various component parts as much as possible and follow the respective recycling, recovery or disposal procedures in accordance with the regulations in force in the countries concerned.

CERAMIC PLATES

COLOUR VARIANTS AND CONFIGURATION OPTIONS

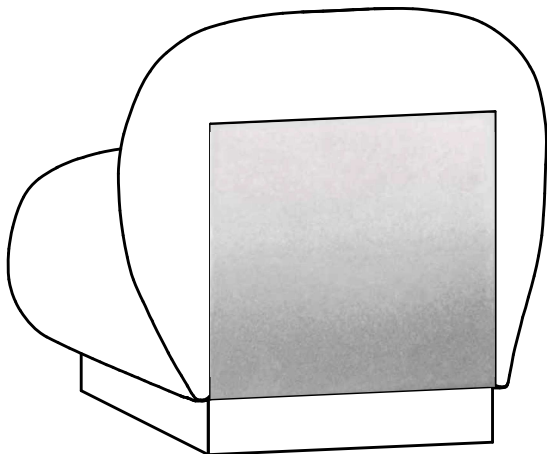

SILVER CLOUD
- monochrome
- **A variant:** darker grey tone DOWN

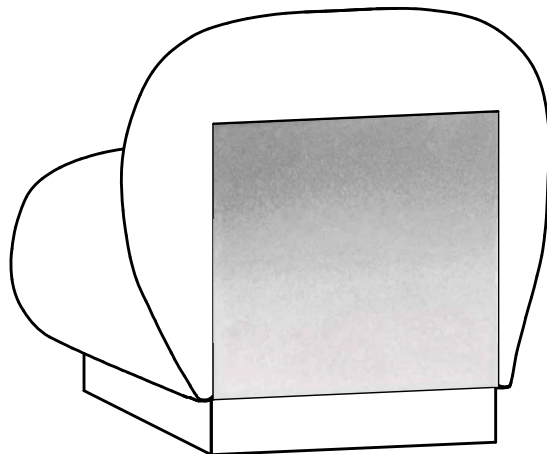

SILVER CLOUD
- monochrome
- **B variant:** darker grey tone UP

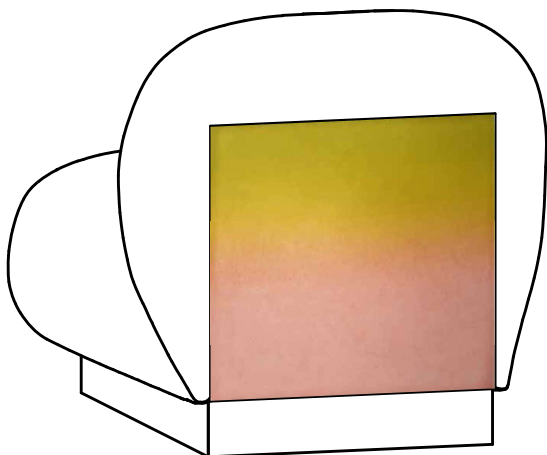

SUMMER ICE CREAM
- two-tone gradient
- **A variant:** pink tone DOWN

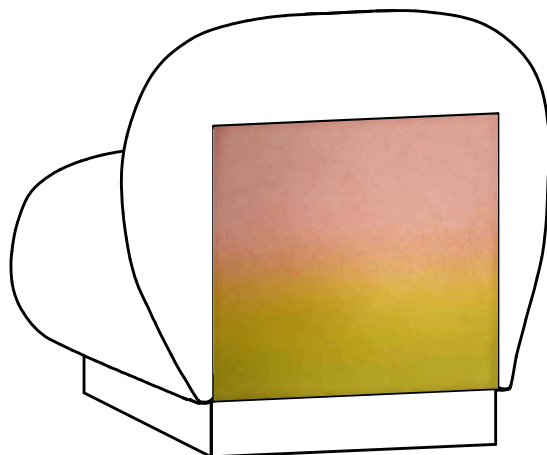

SUMMER ICE CREAM
- two-tone gradient
- **B variant:** pink tone UP

FINISHES: for any doubts or further information regarding care and cleaning, please contact your Moroso representative.

DISPOSAL: in order to respect the environment, it is recommended, at the end of the product's life, to separate the various component parts as much as possible and follow the respective recycling, recovery or disposal procedures in accordance with the regulations in force in the countries concerned.

CERAMIC PLATES

COLOUR VARIANTS AND CONFIGURATION OPTIONS

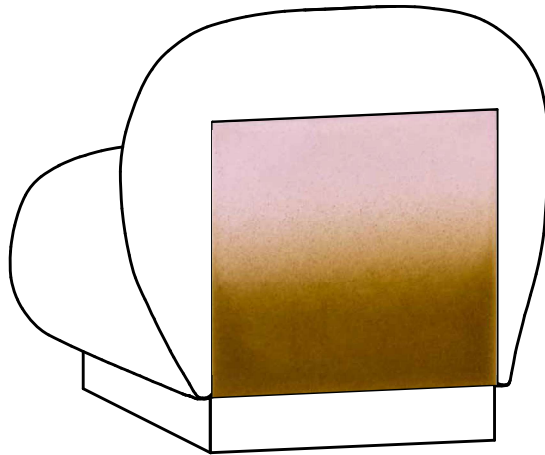

ROSE WOOD
- two-tone gradient
- **A variant:** caramel tone DOWN

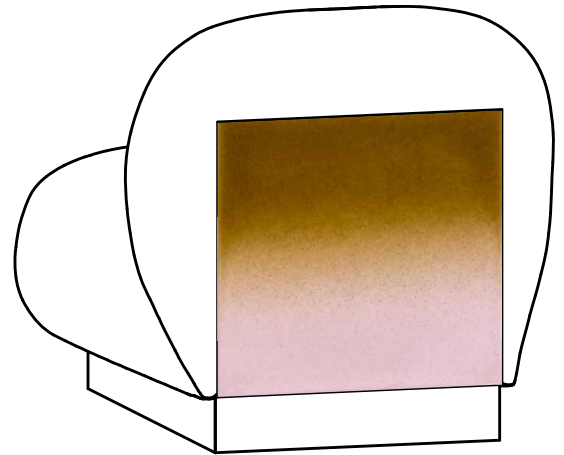

ROSE WOOD
- two-tone gradient
- **B variant:** caramel tone UP

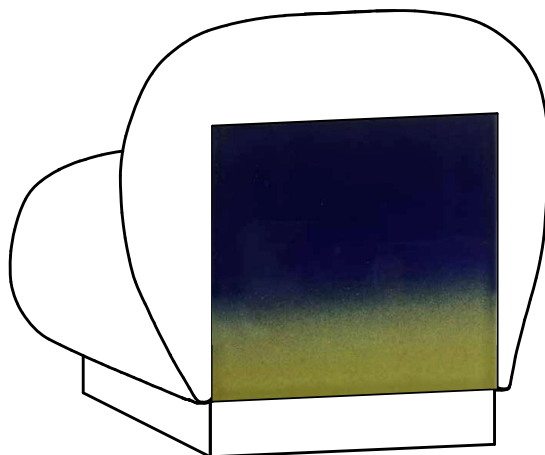

NIGHTY MEADOW
- two-tone gradient
- **A variant:** green tone DOWN

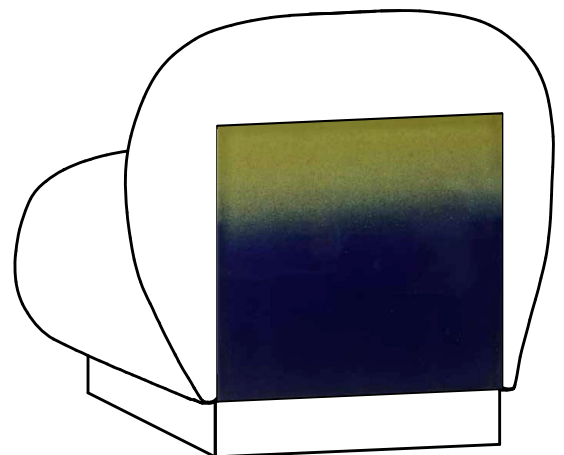

NIGHTY MEADOW
- two-tone gradient
- **B variant:** green tone UP

FINISHES: for any doubts or further information regarding care and cleaning, please contact your Moroso representative.

DISPOSAL: in order to respect the environment, it is recommended, at the end of the product's life, to separate the various component parts as much as possible and follow the respective recycling, recovery or disposal procedures in accordance with the regulations in force in the countries concerned.

CERAMIC PLATES

COLOUR VARIANTS AND CONFIGURATION OPTIONS

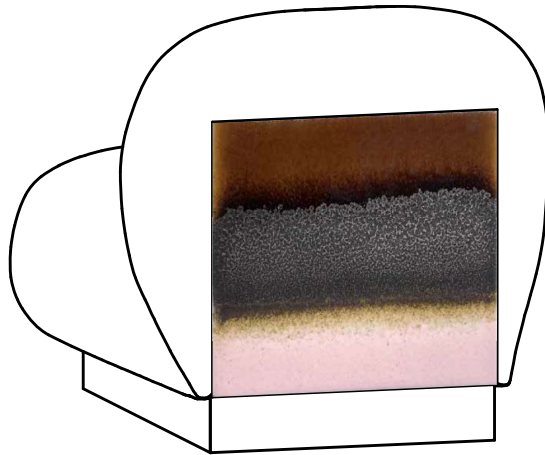

SALTED CARAMEL
- three-tone gradient
- **A variant:** pink tone DOWN

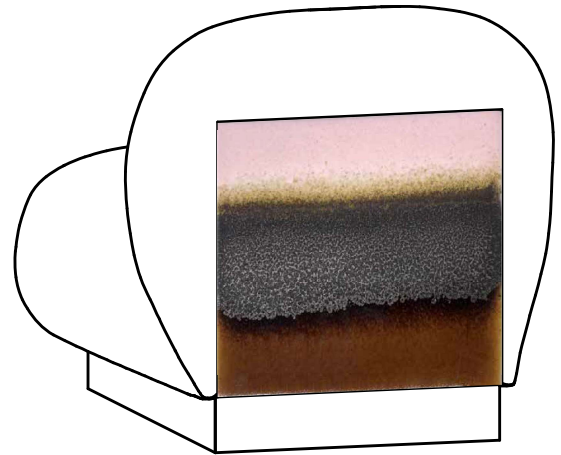

SALTED CARAMEL
- three-tone gradient
- **B variant:** pink tone UP

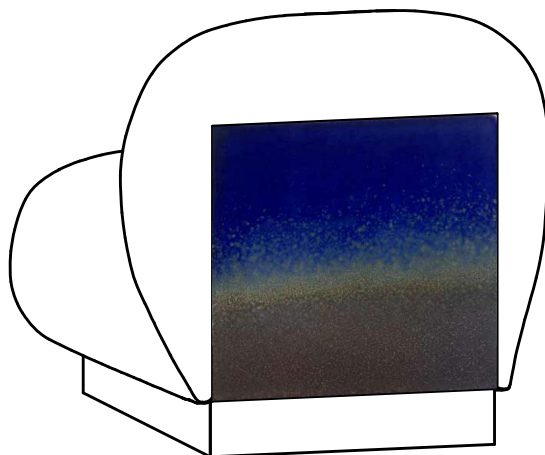

MIDNIGHT SWIM
- three-tone gradient
- **A variant:** dark silver tone DOWN

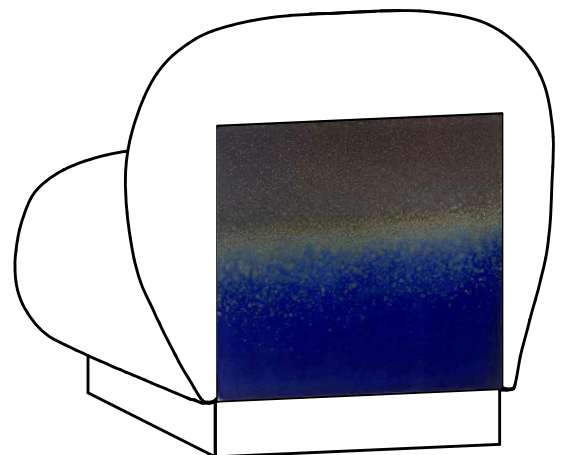

MIDNIGHT SWIM
- three-tone gradient
- **B variant:** dark silver tone UP

FINISHES: for any doubts or further information regarding care and cleaning, please contact your Moroso representative.

DISPOSAL: in order to respect the environment, it is recommended, at the end of the product's life, to separate the various component parts as much as possible and follow the respective recycling, recovery or disposal procedures in accordance with the regulations in force in the countries concerned.

CERAMIC PLATES

COLOUR VARIANTS AND CONFIGURATION OPTIONS

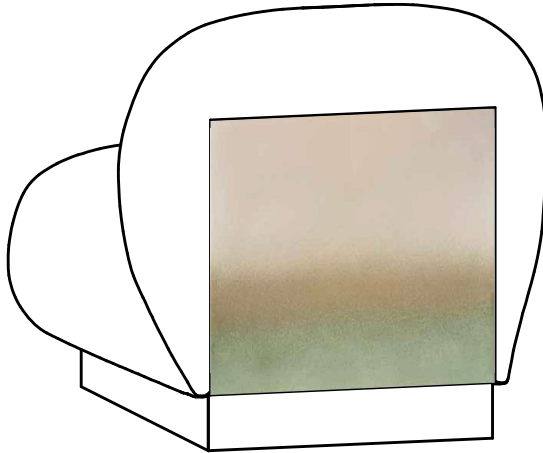

ACQUA ALTA
 - three-tone gradient
 - **A variant:** green tone DOWN

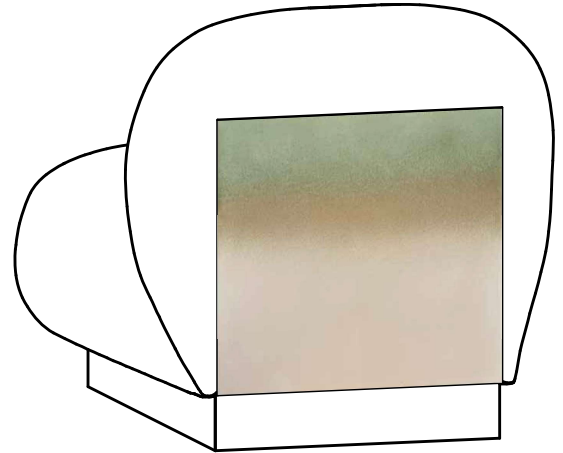

ACQUA ALTA
 - three-tone gradient
 - **B variant:** green tone UP

MAINTENANCE AND CLEANING

The ceramic plate is crafted entirely by hand. It is hand-pressed and glazed through multiple firing cycles.

Any variations in color distribution or surface finish are not to be considered defects, but rather signs of value, attesting to the uniqueness of the artisanal process.

Regular cleaning: these surfaces can be cleaned with a cloth dampened with water and then dried with a soft, dry cloth.

FINISHES: for any doubts or further information regarding care and cleaning, please contact your Moroso representative.

DISPOSAL: in order to respect the environment, it is recommended, at the end of the product's life, to separate the various component parts as much as possible and follow the respective recycling, recovery or disposal procedures in accordance with the regulations in force in the countries concerned.

VENEERED MDF BASE**VENEER VARIANTS**

SOLID OAK



CANALETTO WALNUT

MAINTENANCE AND CLEANING

Regular cleaning: use a soft cloth lightly dampened with water or with mildly soapy water (with pH 7 neutral soap). Rinse with a well wrung-out cloth and thoroughly dry all surfaces. It is always a good rule to avoid using chemical sprays and chemical products in general to clean wooden surfaces.

Do not use: alkaline or abrasive cleaners, soda or solvents, ammonia or acetone. Avoid furniture waxes. Do not use pumice, metal scouring pads, or cloths with rough surfaces.

FINISHES: for any doubts or further information regarding care and cleaning, please contact your Moroso representative.

DISPOSAL: in order to respect the environment, it is recommended, at the end of the product's life, to separate the various component parts as much as possible and follow the respective recycling, recovery or disposal procedures in accordance with the regulations in force in the countries concerned.